



user instructions and warranty

leglifter

freedom

through lightweight solutions

The Leglifter by Mangar International enables people to raise their legs onto the bed independently or with minimal assistance. Power is provided by the Mangar International Airflo compressor.

PLEASE READ the separate Airflo compressor instructions before using your Leglifter. When properly maintained, the Leglifter will give many years of trouble free service.



WARNINGS

- Ensure that you have read and fully understand these and the separate Airflo compressor user instructions before using the equipment.
- Only use a Mangar International air supply to inflate the Leglifter.
- Ensure that the Leglifter does not come into contact with sharp objects.
- Ensure that the Airflo compressor, air hose and hand control are positioned so as not to present a tripping hazard.

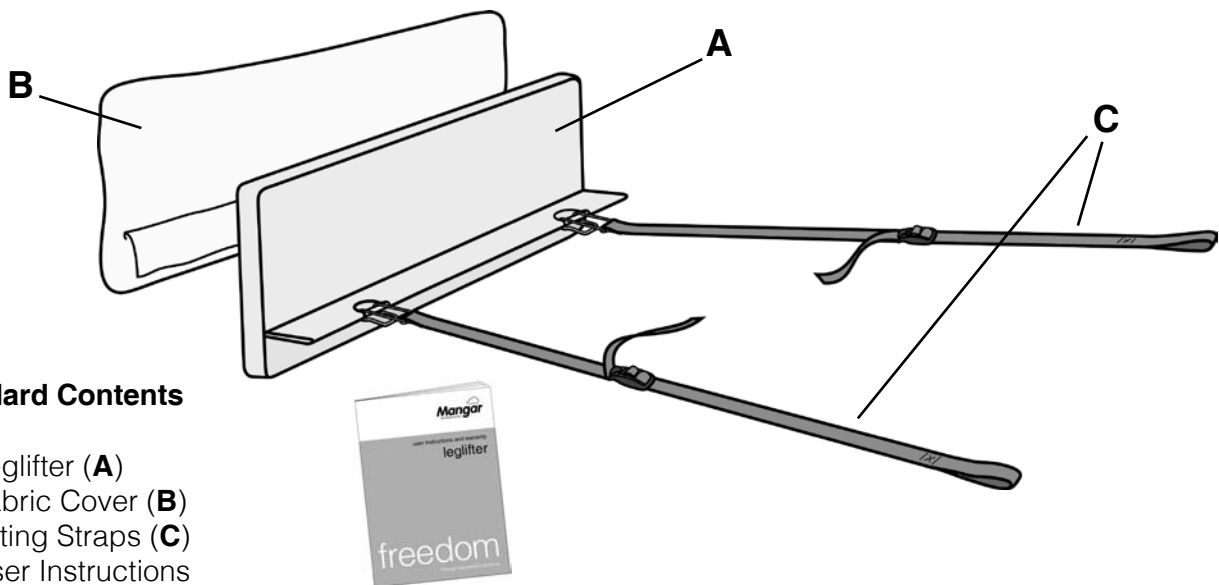

Standard Contents

- 1 x Leglifter (A)
- 1 x Fabric Cover (B)
- 2 x Fitting Straps (C)
- 1 x User Instructions



Standard fitting instructions

- Fit the looped end of each strap around the legs, castors or bed frame on the opposite side of the bed (**A** fig. 1) and pass the straps under the mattress.
- Fit the hook of each strap onto the Leglifter flap (**B** fig.1) and position the Leglifter loosely alongside the bed, clear of any obstacles such as a bedside table.
- Tighten the straps to pull the edge of the flap ('Vee' of deflated Leglifter) under the mattress by approximately 1 to 2 fingers width (**C** fig.2).
- Connect the Leglifter air hose and hand control (**D** fig.3) to the Airflo as indicated in the separate Airflo compressor user instructions.

NOTE: Select 'Normal' on the switch located on the underside of the Airflo compressor (see separate Airflo compressor user instructions).

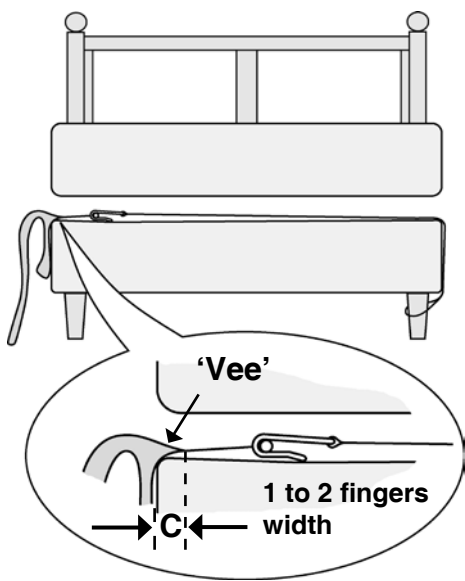

- Test that the Leglifter inflates to fully vertical against the mattress and further tighten the straps if necessary.

NOTE: Upon final adjustment, the edge of the flap settles to sit on the frame/divan (under the mattress) by about 1 to 2 fingers width. This will vary according to bed type e.g. divan, sprung divan, narrow framed bed.

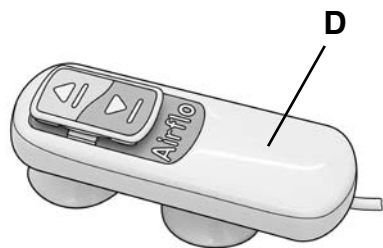

- Place the Airflo compressor by the side or under the bed in an out of the way position.

Fitting instructions (Profiling Beds)

The flexible construction of the deflated Leglifter makes it ideal for use with most types of profiling bed. However, please carefully follow these guidelines to avoid any conflict with moving sections of the bed.

- Remove the mattress from the bed.
- Raise and lower the backrest and legrest sections of the bed to identify strap positions which best avoid chafing/fouling of the straps.
- On the opposite side of the bed to where the Leglifter is to be fitted, secure the loop end of each strap to the inner frame as indicated (**A** fig.4). **NOTE:** Wrap the strap around the frame several times so as to shorten the strap length, allowing the adjuster buckle to lie near the centre line of the bed.

WARNING: When fitting to a bed with a Low/High function, ensure that the straps are attached to the frame which moves up and down.

- Hook the two straps onto the flap of the Leglifter as indicated in (**B** fig.4) and pull on the strap at the adjuster buckle to draw the 'Vee' of the deflated Leglifter inwards over the bed frame and under the mattress by about 1 to 2 fingers width (**C** fig.5).
- Raise and lower the backrest and legrest sections of the bed, checking to ensure that the straps do not interfere with the bed's functions.
- Replace the mattress.
- Connect the Leglifter to the Airflo compressor and with the backrest and legrest sections of the bed in the horizontal position, test that the Leglifter inflates to fully vertical against the mattress. Tighten the straps further if necessary. Upon final adjustment, the edge of the flap settles to sit on the frame (under the mattress) by about 1 to 2 fingers width.

NOTE: Normally, the Leglifter should be operated with all bed sections in the horizontal position. If necessary, the backrest can be raised up to 45° to assist upper body stability while the legs are raised.

WARNINGS:

- Do not operate the Leglifter when the bed's legrest is raised.
- Do not raise the bed's legrest when the Leglifter is inflated.
- Always deflate the Leglifter after the legs have been safely positioned on the bed.

NOTE: Where fitted, any integral cotside on the transfer side of the bed must be removed to permit effective fitting and operation of the leglifter.

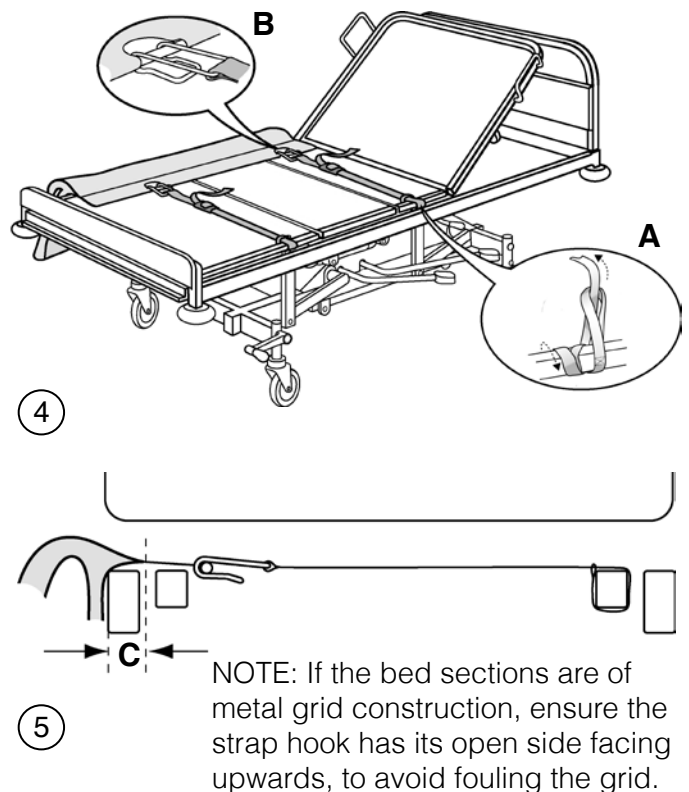

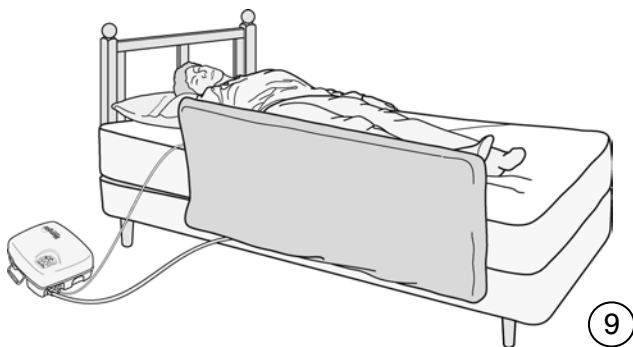
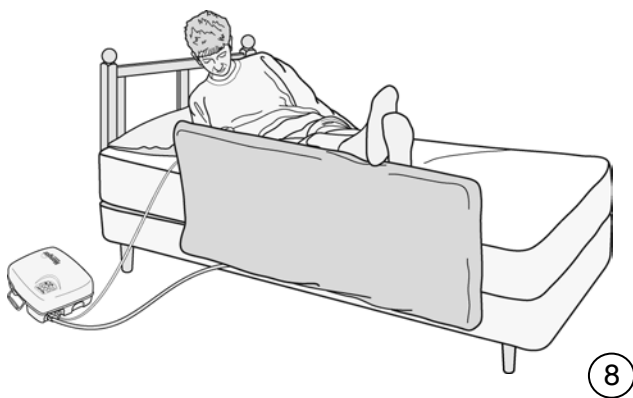
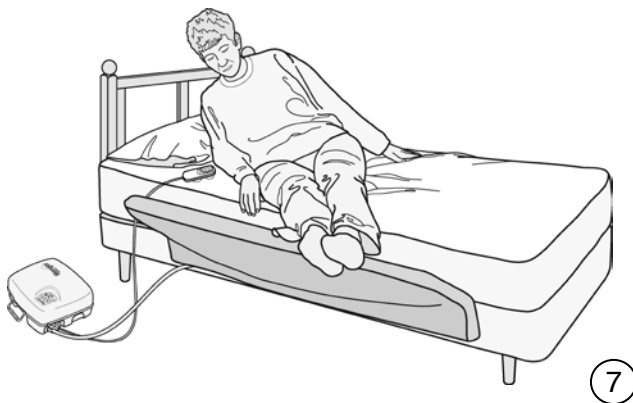

Operating instructions

- Sit on the bed at your normal entry point and as far across the bed as possible. Angle your legs towards the foot of the bed as far as is comfortable (fig. 6). If possible, use one arm for support as illustrated, until you are ready to lie down. Some clients prefer to use a bed lever for this purpose.
- To lift your legs onto the bed, press 'up' on the hand control. Release the 'up' button to stop at the half-way stage and/or any convenient point and adjust your position to improve the angle of your legs (fig. 7).
- Fully raise the Leglifter, allowing your legs to slide along the cushion and gently drop onto the bed (figs. 8 & 9).
- Deflate the Leglifter by holding the 'down' button for a few seconds; release the button and the Leglifter will carry on deflating.

Cleaning

routine cleaning

- Remove the cover. Fully inflate the Leglifter, sponge clean with a detergent solution and dry thoroughly. **Do not dry using hot air.**
- The cover can be machine washed up to 40°C; low heat tumble dried and medium heat ironed. Do not dry clean or use bleach.

disinfection

- Remove the cover. Fully inflate the Leglifter and pre-clean by washing with detergent and water and then disinfect using either buffered hypochlorite (such as 'Milton' solution) or a hard surface, alcohol impregnated wipe. **Do not dry using hot air.**

Storage

Ensure that the Leglifter is thoroughly dry before storing. Store deflated.

Maintenance

- Periodically check the air hose for signs of damage or wear.
- Periodically check the fitting straps for signs of damage or wear.
- Regularly launder the cover and allow to thoroughly dry before refitting.

We recommend that your Leglifter is inspected annually by either your supplier or other suitably qualified person. If required, Mangar International can provide full maintenance within an annual service contract. Please contact our Customer Care department for further details (**See page 7 for further information**).

Repairs or servicing must only be carried out by your supplier or other authorised person.

Specifications

(Inflated) 124cm x 57cm x 10cm
Max. Air Pressure: 0,35 bar (5psi)
Max. Temperature: 50°C

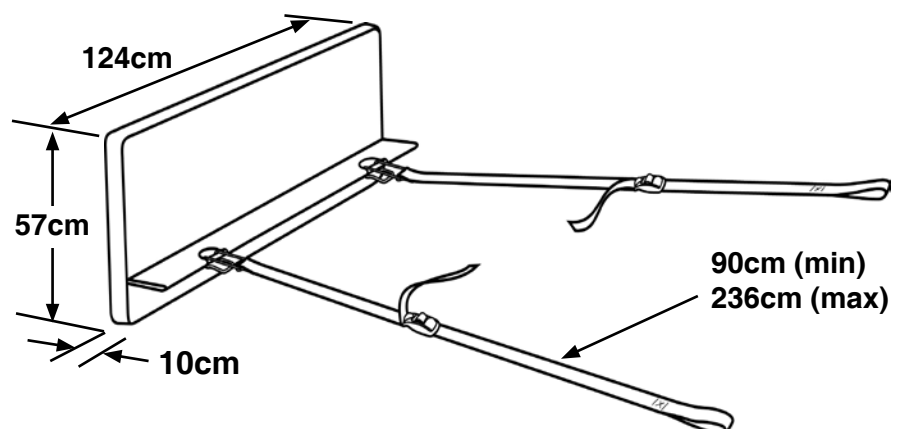

Warranty

The guarantee is given against defects in material and workmanship and comprises piece, parts and labour. The guarantee is not valid in the case of fair wear and tear, wilful damage, common neglect, misuse or unauthorised alteration or repair by unqualified persons.

The following statements do not affect the consumer's statutory rights. This product is sold on the understanding that in the event of any defect of manufacture or material appearing within the warranty period, the defect will be rectified free of charge providing that:

- (a) Reasonable evidence is provided (e.g. purchase invoice, delivery note) that the claim is being made within the warranty period.
- (b) The defect is not attributable to accidental damage (either in transit or otherwise), misuse or unauthorised repair.

Leglifter serial number:
Date of purchase:
Invoice/Delivery note number:



We strive to provide our customers with reliable and durable products of the highest quality. In addition to our standard warranty, and for added peace of mind, our servicing division, Primeserve, also offers a variety of service options. Choose from an **Extended Parts Warranty**, **Call-Out Protection** and an **Annual Service and Clean**.

To find out how we can provide complete cover for your Mangar International product call our Customer Care Department on **Freephone 0800 280 0485**.

Mangar International reserves the right to alter product specifications and/or any of the information contained within this document without notice.

freedom through lightweight solutions



Mangar International

Presteigne

Powys

Wales, UK

LD8 2UF

tel: +44 (0)1544 267674

fax: +44 (0)1544 260287

customer care@mangar.co.uk

www.mangar.co.uk

Patented



MI0003 issue 8
(09/11)